

500 Series Thermal Switches

Commercial and Military

Honeywell's 500 Series switches are ideally suited for applications where exceptional reliability, rapid temperature response, and consistently high quality are key requirements. They may be used to control, indicate or limit a variety of temperature functions.

These single pole, single throw switches are hermetically sealed using all-welded construction. A calibrated bimetal, snap-acting disc provides the energy to open and close electrical contacts at pre-specified temperature settings.

The 500 Series switches are manufactured in a controlled environment with temperature setpoints tested by a computer to assure accuracy and uniformity. The discs are 100% tested prior to assembly,

Nine standard mounting configurations are available. They are easily adaptable for special designs in industrial, aeronautic, and military applications, and are qualified to MIL-PRF-24236/1.

Application Examples

- Electronics compartment temperature control
- Industrial bath temperature control
- Gyro/accelerometer system temperature control
- Duct air temperature control
- Motor overheat protection
- Hydraulic pump/system overheat protection
- Bearing overheat warning
- Gearbox overheat warning
- Battery charge rate and overtemp control
- Heatsink overtemp warning
- Surface and strip heater control



Features

- All welded hermetic construction
- Operating temperatures available from -65°F to +350°F
- High vibration resistance
- High and low current capability
- Crisp SPST contact operation
- Fast response to thermal changes
- Lightweight and rugged
- Backfilled with dry Nitrogen gas containing 10% Helium trace
- Tested to 63.5g rms random vibration levels
- Special materials and finishes can be provided
- Custom units available to over +600°F
- Non-standard tolerances available upon request
- Additional configurations available (consult factory)

Custom Features

- Special terminal configurations, plating, overmolds and lead wires are available (consult factory).
- Unusual temperature ranges and setpoint tolerances available (consult factory).
- Special identification requirements.
- Custom shapes, assemblies, materials and finishes can be provided.

Specifications for 500 Series Thermal Switch

Performance Characteristics

Contact Arrangement:	SPST
Contact Ratings:	5 amps resistive load at 28 VDC 2 amps resistive load at 115 VAC RMS 1.0 amp inductive load (L/R 0.02) at 28 VDC
Contact Resistance:	20 milliohms maximum
Endurance	100,000 cycles minimum at rated DC or AC load
Dielectric Withstanding Voltage:	1500 VAC RMS - terminals to case, 500 microamperes maximum leakage
Insulation Resistance	500 megohms minimum at 500 VDC

Environmental (MIL-STD-202)

Vibration (Sine):	Method 204, 50g to 2000 Hz, 30g to 2000 Hz
Vibration (Random):	Method 204, over 60g RMS, 20 to 2000 Hz
Shock:	Method 213, 100g/6ms, 750g/0.5ms
Thermal Shock:	Method 107, Condition B, -85° to +257°F (-65°C to 125°C)
Acceleration:	Method 212, Condition A, 30g
Salt Spray:	Method 101, Condition B, 48 hours
Moisture Resistance:	Method 106, 240 hours, 90 - 98% RH and from +77°F to +149°F (+25°C to 65°C)
Hermetic Seal:	Method 112, Condition C, Procedure IV

NOTE: The 500 Series thermal switches have been qualified to the requirements of Military Specification MIL-PRF-24236, titled "Switches, Thermostatic, General Specification For"

Tolerance Limits

(Consult Factory for Non-Standard Limits)

Specified Temp Setpoint Range °F (°C)	Standard Setpoint Tolerance °F (°C)
-65 to 0 (-54 to -18)	±6 (±3.3)
+1 to 250 (-17 to 121)	±5 (±2.8)
251 to 350 (122 to 177)	±7 (±3.9)

Lower, upper and minimum differential temperature tolerance may be reflected as **CLOSE TOLERANCE / OPEN TOLERANCE / DIFFERENTIAL**.

EXAMPLE: /5/5/7 where Close Tolerance = ±5°, Open Tolerance = ±5°F, Differential = 7°F min.

Sample Ordering Code

Once written, your ordering code becomes the specific part number, as this example illustrates:

1	2	3	UNIT # 4	5	6	7
571	T	150	A	160	XX	

Configuration shown in drawing

T = Tin lead finish

Lower temperature setpoint at 150°F ±5°F

A = Open on temperature rise

B = Close on temperature rise

Upper temperature setpoint at 160°F ±5°F

Custom features and temperature tolerances (consult factory)

Configuration Modifiers (consult factory)

Configuration Drawings (dimensions in inches)

All configurations shown are available with upright terminals

571

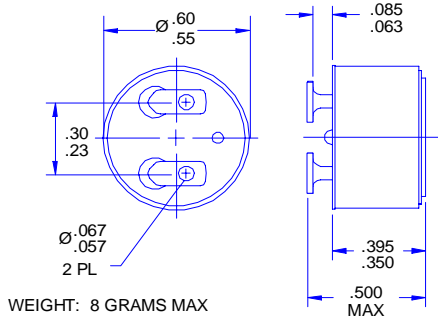

572

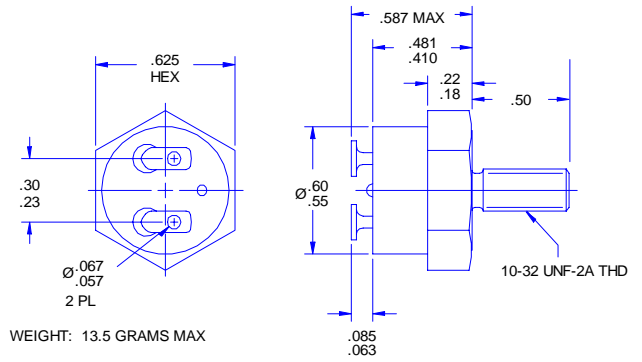

573

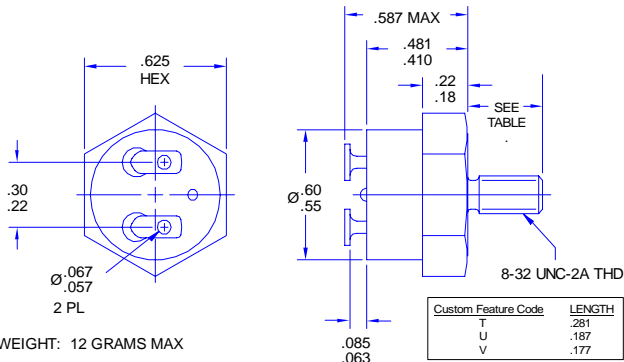

574

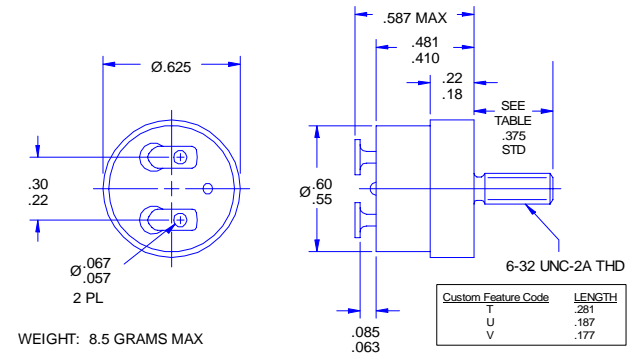

575

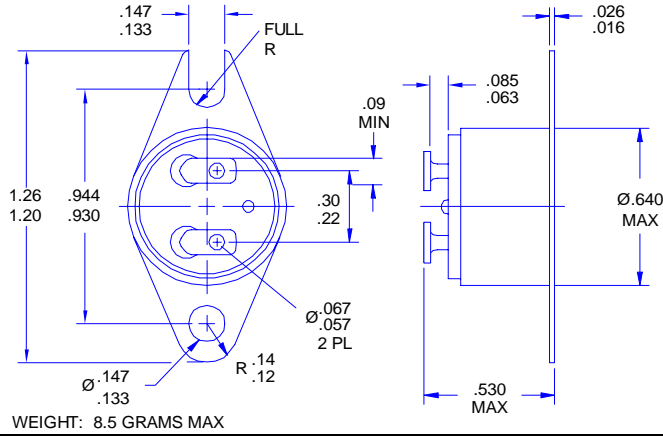

576

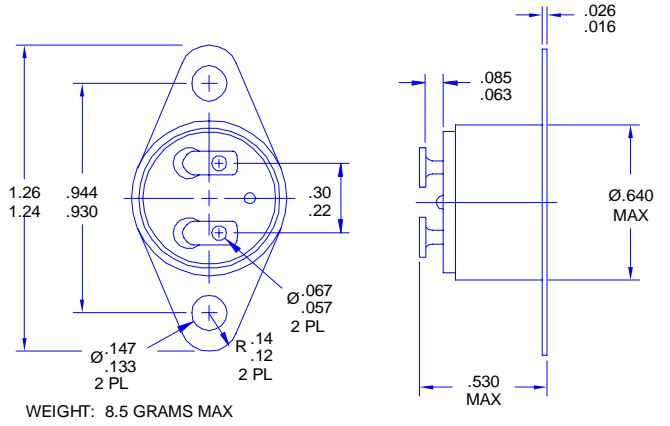

577

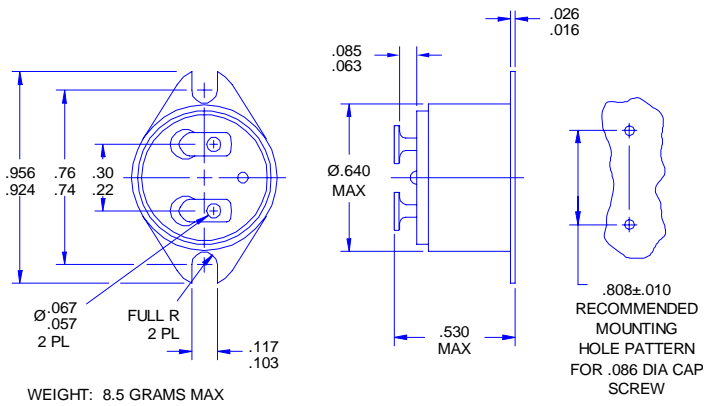

578

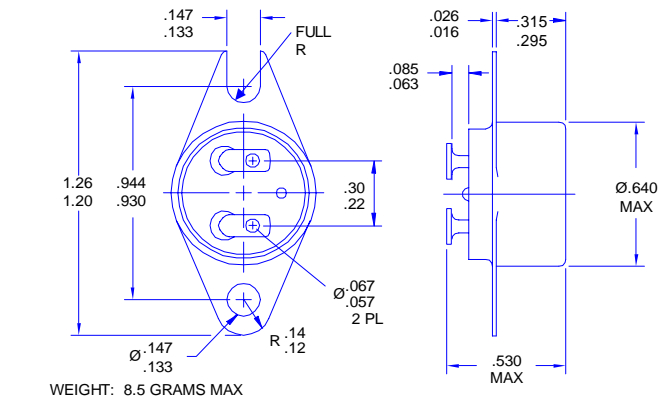

Configuration Drawings (dimensions in inches)

All configurations shown are available with upright terminals

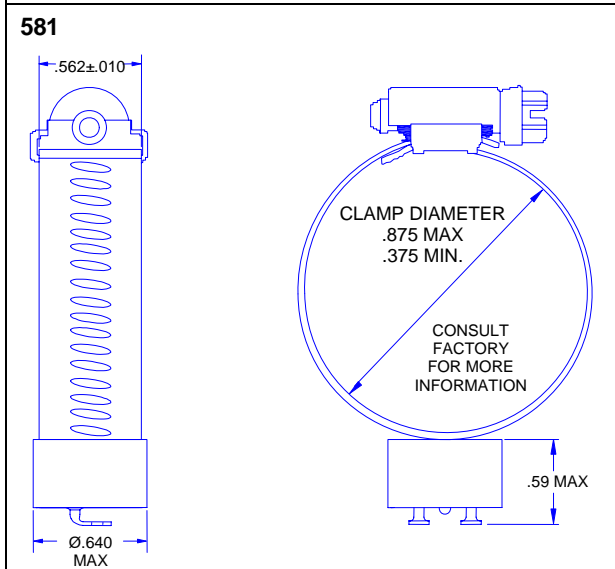
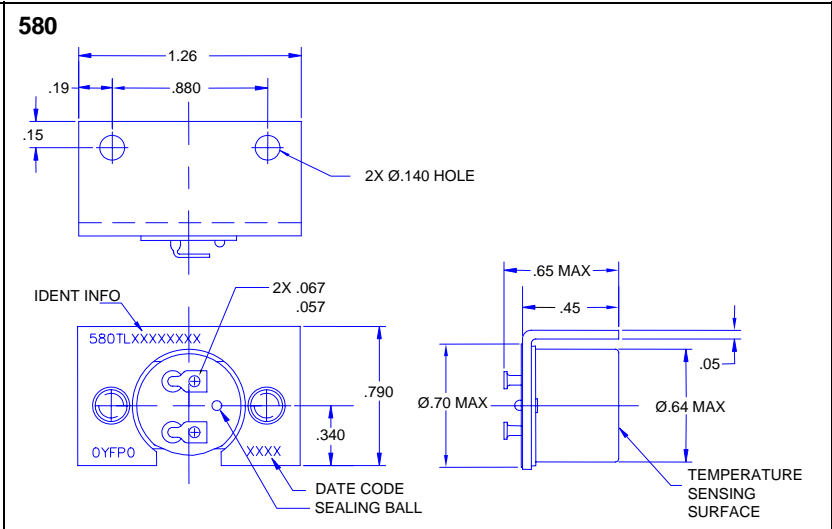
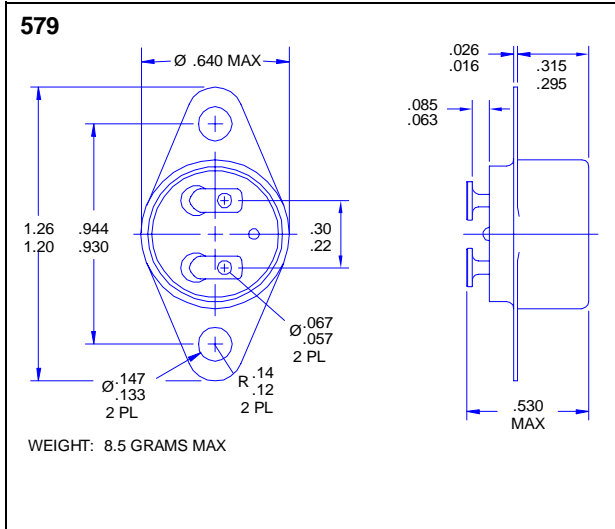

Find out more:
www.thermalswitch.com

Defense & Space Redmond

Honeywell International, Inc.
 MAIL ADDRESS: P.O. Box 97001
 15001 N.E. 36th Street
 Redmond, Washington 98073-9701
 PHONE: 888 206 1667
 FAX: 425 883 2104
www.honeywell.com

500 12/2006 EXP052
 Copyright © 1994, Honeywell
 International Inc. All Rights
 Reserved. Printed in USA

ISO-9001 Certification Since 1995

DISCLAIMER: Specifications are subject to change without notice. Honeywell reserves the right to make changes to any product or technology herein to improve reliability, function, or design. Honeywell does not assume any liability arising out of the application or use of the product.

