

650 Series Thermal Switches

Commercial and Military



Honeywell's new 650 series thermal switch is a value engineered product derived from the industry standard 700 Series High Reliability product line. It is specifically designed to meet the growing demand for low cost space qualified thermostats.

By incorporating the same design features found on our 500 series and adapting processes established in our 700 series, the 650 series offers a low cost way to meet thermal management requirements in the demanding space environment.

All switches are thoroughly tested, and meet or exceed the requirements set forth in MIL-PRF-24236/1, Type I, Class 4.

Upon testing and inspection, Honeywell serializes each switch, provides the customer with an acceptance test data sheet.

Off-the-shelf designs are available to save time and engineering resources by eliminating charges for customer specifications and non-recurring engineering charges.

No matter what your high-reliability application may be, Honeywell has the right solution for your system.

Application Examples

- Electronics compartment temperature control
- Cold plate temperature monitoring and control
- Optics and instrumentation temperature control
- Surface and strip heater control
- Battery charge rate and heater control
- Rocket motors and thrusters
- Overheat protection
- Electric motor pre-heater control
- Hydraulic/pneumatic actuator freeze protection systems
- Environmental control system limit indication and control

Features

- All welded steel construction, plated
- 500 cycles of run-in while monitoring contact resistance
- Able to withstand high vibration and shock levels
- Crisp, snap-action contact operation
- Meets or exceeds requirements of MIL-PRF-24236
- Small and lightweight, yet rugged
- Internal cleanliness 100% verified by micro-particle analysis
- Each switch serialized and shipped with individual test data sheet
- Low contact resistance: 25 milliohms maximum
- Hermetically sealed & backfilled with dry Nitrogen & 10% Helium tracer

Configuration Drawings (dimensions in millimeters)

All configurations shown are available with upright terminals

651

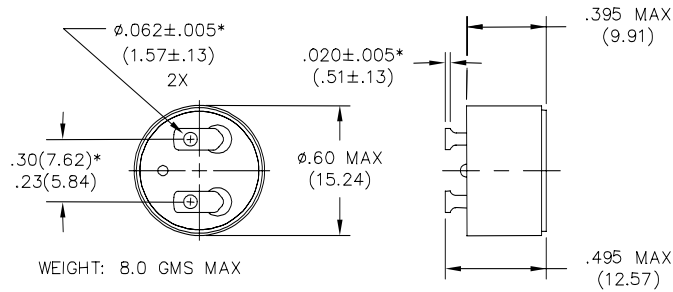

652

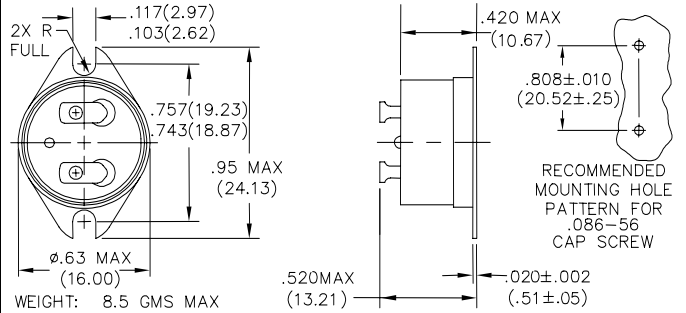

653

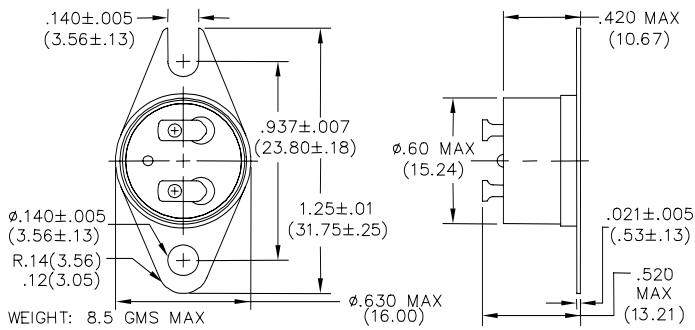

654

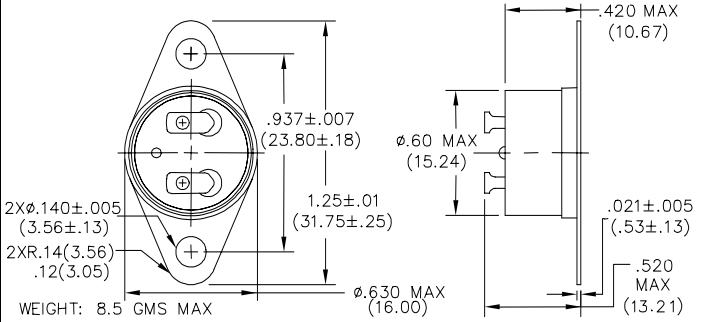

655

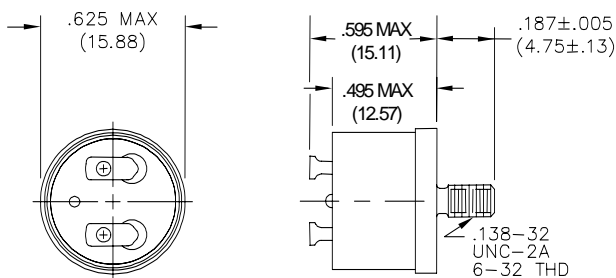

656

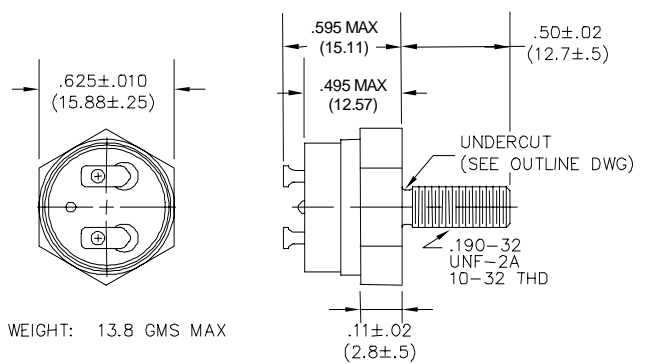

657

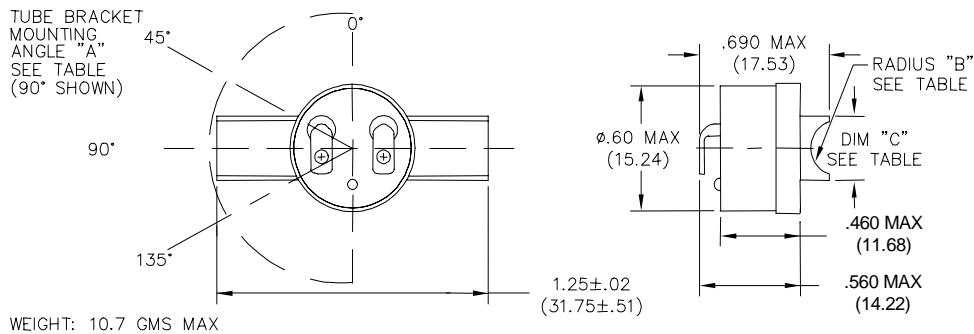

ORDERING CODE (UNIT 7A)	ANGLE "A"
A	±10°
B	0°
C	45°
D	90°
	135°

ORDERING CODE (UNIT 7B)	RADIUS "B"	DIMENSION "C"
1	R.125	.29 (7.37)
2	R.187	.43 (10.92)
3	R.250	.43 (10.92)

Specifications for 650 Series Thermal Switch

Performance Characteristics	
Contact Arrangement	SPST
Contact Ratings	5 amperes resistive load at 28 VDC 2 amperes resistive load at 115 VAC RMS 1.0 ampere inductive load (L/R 0.02) at 28 VDC, 115 VAC RMS 1.0 ampere lamp load at 28 VDC/115 VAC RMS
Dielectric Withstanding Voltage	1250 VAC RMS - terminals to case, 500 microamperes maximum leakage
Insulation Resistance	500 megohms minimum at 500 VDC
Endurance	100,000 cycles minimum at rated load
Ambient Temperature Range	-100°F to 300°F
Wire (where applicable)	MIL-S-22759/43
Environmental (MIL-STD-202)	
Vibration (Sine)	Method 204, 50g to 2000 Hz, 30g to 3000 Hz
Vibration (Random)	Method 214, over 30g RMS, 20 to 2000 Hz
Moisture Resistance	Method 106, 240 hours, 90-98% RH, & from +77°F to +149°F (+25°C to 65°C)
Hermetic Seal	Method 112, Cond. C, Procedure IV, 1.0×10^{-8} Atm, cc/sec max leak rate
Solderability	Method 208
Shock	Method 213, 100g/6ms, 750g/0.5ms
Thermal Shock	Method 107, Condition B, -85°F to +257°F (-65°C to 125°C)
Acceleration	Method 212, Condition A, 30g
Salt Spray	Method 101, Condition B, 48 hours

Acceptance Test Data

Test	Criteria
Contact resistance monitored burn-in	500 cycles min, 100 mΩ max
Particle impact noise detection (PIND)	No particle noise
Calibration/setpoint	3 cycles
Creepage (ARC duration) 3 cycles	<5 msec, 600 VDC
Seal: fine leak gross leak	$\leq 1 \times 10^{-8}$ Atm. cc/sec No bubbles
Contact resistance - 3 cycles	25 milliohms max (6 VDC, 0.1A)
Dielectric withstanding voltage - Terminals to case	1250 VAC RMS, 60 Hz
Insulation Resistance, Terminals to case	500 megohms minimum at 500 VDC
Weight	Varies by configuration
Inspection of product	Final visual

Sample Ordering Code

Once written, your ordering code becomes the specific part number, as this example illustrates

	UNIT #						
	1	2	3	4	5	6	7
Configuration shown in drawing	657	TL	040	A	060	/5/5/7	/C1
TL = Tin/Lead Plated N = Nickel Plated							
Lower temperature setpoint at 40°F							
A= Open on temperature rise B = Close on temperature rise							
Upper temperature setpoint at 60°F							
Lower, Upper and Minimum Differential Temperature Tolerance (see following list)*							
Special Physical Feature (see individual configuration drawing), "1" is required for proper designation							

UNIT 6: Non-standard tolerances may also be defined by the ordering code by using a "/" separator. For example: 657S133A155/4/4/7 specifies $\pm 4^\circ\text{F}$ tolerance on UNIT 3 temperature, $\pm 4^\circ\text{F}$ tolerance on UNIT 5 temperature, and 7°F minimum differential

Tolerance Limits (Consult Factory for Non-Standard Limits)

Specified Temp Setpoint Range °F (°C)	Standard Setpoint Tolerance °F (°C)
-85 to 0 (-65 to -17.8)	±6 (3.3)
+1 to 250 (-17.2 to 121.1)	±5 (2.8)
251 to 302 (121.7 to 150)	±7 (3.9)

NOTE: The 650 Series thermal switches have been qualified to the requirements of Military Specification MIL-PRF-24236, titled "Switches, Thermostatic, General Specification For," for Type I, Class 4 devices.

Temperature Tolerance

- A Setpoints are min-max, Specify differential minimum tolerance.
- B Opening setpoint is min or max. Specify closing tolerance and differential tolerance.
- C Closing setpoint is min or max. Specify opening tolerance and differential tolerance.

Find out more:

www.thermalswitch.com

Defense & Space Redmond

Honeywell International, Inc.
MAIL ADDRESS: P.O. Box 97001
15001 N.E. 36th Street
Redmond, Washington 98073-9701
PHONE: 888 206 1667
FAX: 425 883 2104
www.honeywell.com

TS650 EXP044 -11/2005
Copyright © 2000, Honeywell
International Inc. All Rights
Reserved. Printed in USA

ISO-9001 Certification Since 1995

DISCLAIMER: Specifications are subject to change without notice. Honeywell reserves the right to make changes to any product or technology herein to improve reliability, function, or design. Honeywell does not assume any liability arising out of the application or use of the product.

THERMAL SWITCHES exported from the United States must be done in accordance with the Export Administration Regulations (EAR) and/or the International Traffic in Arms Regulations (ITAR) as applicable.

